

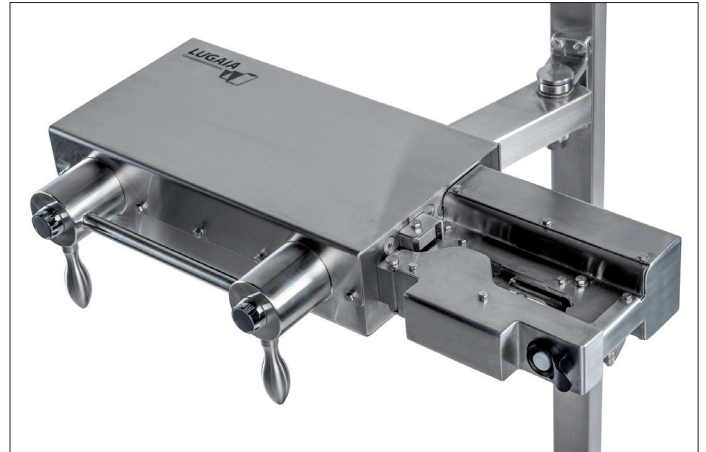

Lugaia SafeSeal Pneumatic Tool

With the SafeSeal Pneumatic Tool, a closure system has been developed which is characterized by simple operation, high working safety, universal usability and high quality.

A containment Level OEB 5 ($<1\mu\text{g}/\text{m}^3$) is ensured in combination with the SafeSeal closures and the films of the continuous-liner system (CLS: standard sizes see own product sheet).



The SafeSeal Pneumatic Tool is used in end of line packaging applications and complies with the following features:

- Available for SafeSeal closure size M and L
- Automatic pressing and cutting of SafeSeal closures
- Fully pneumatically operated (ATEX-compatible)
- Made of stainless steel
- High security by two-hand operation
- Integrable to existing system



SafeSeal Pneumatic Tool Handling

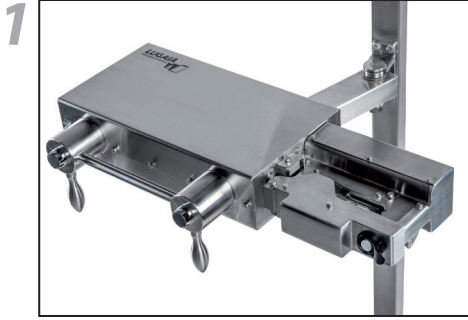

SafeSeal Pneumatic Tool



Open SafeSeal Pneumatic Tool

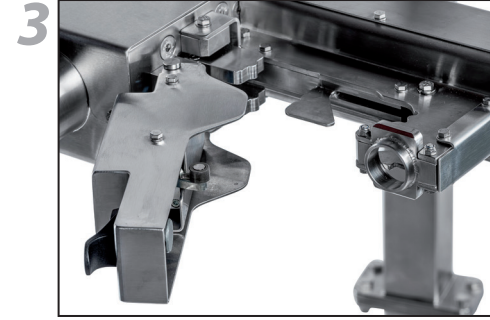

Initial state

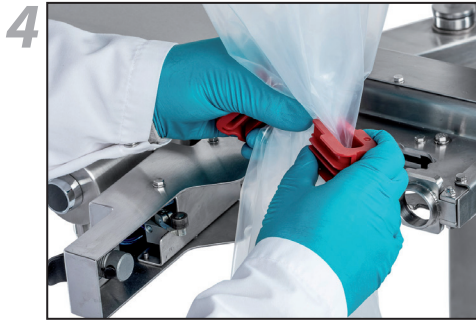

Insert film into the crimp



Insert crimp counterpart

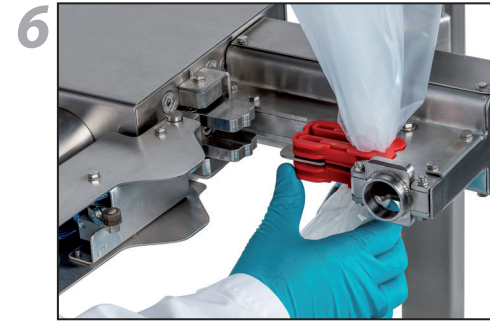

Place SafeSeal crimp

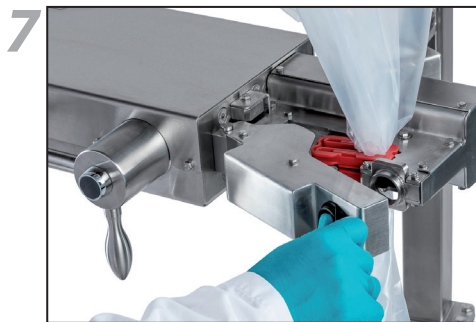

Close SafeSeal Pneumatic Tool



Safe pressing and cutting in two-handed operation



Both parts are tightly closed and can be removed after opening the tool