

DIOSNA. Process Systems for Laboratories and Pilot Plants



Pharmaceutical Mixer 0,25 to 150 l

Mixing, granulation and vacuum drying.

DIOSNA DIERKS & Söhne GmbH · Am Tie 23 · 49086 Osnabrück · Germany
Telefon: +49 541 33104-0 · Telefax: +49 541 33104-805
info@diosna.com · www.diosna.com



Quality, experience and innovation



Vacuum drying:
Tool blade with stripper.



Standard mixer granulator:
elevated blade tips



Simple and comfortable:
Control by industrial PC.

Flexibility in Laboratories and Pilot Plants

DIOSNA offers a versatile range of machines for laboratories, pilot plants and small scale production. All systems are designed for a scale-up to larger machines and an ergonomic and easily cleanable design in line with GMP.

Thanks to our extensive range of accessories and numerous upgrade options, each machine can be flexibly adapted to your requirements or systematically extended at a later stage.

Would you like to test our machines in our laboratory? If so, please feel free to arrange a demonstration date with us. DIOSNA also provides the right equipment for special technologies such as pelletising, thermogranulation or micro-granulation.

Different containment-designs are available for processing of highly potent materials.

DIOSNA machines with interchangeable bowls are prepared for use with different sized bowls. This gives our customers optimum flexibility for the future without having to invest in equipment which they do not require immediately.

The installation of an industrial PC is also beneficial for laboratory and pilot scale machines. The software used by DIOSNA conforms to 21 CFR Part 11 and offers a user-friendly visualisation as well as extensive batch data logging and documentation. Our programmers are known for rapid support via the integrated modem. An efficient and comforting service which has proved very successful.



Mixing and granulating wet granules

P 1 - 6 Laboratory Mixer



Discharge valve, chopper coupling and safety switch.



5.7" Touch Pad.



Controls with tablet PC.

- Practical, user-friendly bench top version, simple to clean
- Compact, comfortable and easy to operate
- Interchangeable bowls 0.25, 0.5, 1, 2, 4, 6 litres
- PTFE shaft seal, can be dismantled without tools
- Variable speed drives - The speed is adjusted to the relevant bowl size
- PLC with touch screen panel
- Split design available for installation in isolator
- Bowls are optionally available with jacket and temperature measurement
- optional side discharge ports
- Easy Bowl changing thanks to pneumatically operated chopper coupling
- A limit switch assures that the machine is not operated with the bowl open



P 1 - 6
Laboratory Mixer.

In basic design the mixer is equipped with a 5.7" Touch Pad (TP 700, Siemens) and a Siemens PLC S7-1500. Alternatively to the operation by the Touch Pad we offer a tablet PC. The robust PC (IP 65) communicates with the integrated PLC via WLAN and (upon request) with the network of the customer.

The software for the tablet pc (Wonderware InTouch) corresponds to those of the "big DIOSNA's" and allows extremely comfortable visualization, operation and batch reporting. Manual and automatic operation are possible. For the impeller the number of revolutions, the tip speed and the Froude number are displayed.

Mixing, granulation and vacuum drying

Laboratory System P/VAC - 10

- Moveable compact machines with integrated control
- Mixing/Granulating bowls for 0,25; 0,5; 1; 2; 4; 6; 8 and 10 litres
- Vacuum drying bowls 2, 6 and 10 litres
- PTFE shaft seal, can be dismantled without a tool
- Transparent vessel lid made from glass
- Vacuum and/or heating/cooling system can be integrated in the machine
- PLC with touch screen panel Siemens TP 1200
- Explosion protection version and integrated industrial PC available
- Easy bowl changing thanks to pneumatically operated chopper coupling
- Optional side discharge ports
- Split design available for installation in an isolator (glove box)
- Connections for Split Butterfly valves and soft isolator
- Current and power measurement for granulation end point detection



P/VAC - 10 in Isolator version.



P/VAC - 10 with operator panel Siemens TP 1200. 6 l bowl with discharge valve.



Detail Isolator Installation with vacuum drying.

The P/VAC - 10 is a powerful laboratory machine for a very wide range of applications. It covers the entire spectrum of type P 1 - 6. It is also possible to work with bowl sizes up to 10 l. The machine is especially suitable for users who work with organic solvents or highly active substances, who wish to dry in the mixer (one pot processing) or for those who attach considerable importance to a userfriendly control system.

Laboratory System P/VAC 10 - 60

- Moveable compact machine with integrated control Siemens S7 1500
- Mixing/Granulating: Interchangeable bowls 10 l, 25 l, 60 l (also 12 bar shockproof)
- Gas-stripping vacuum drying: 20 l and 50 l
- Easy bowl changing using a movable lifting device
- The drives, outlet and shaft seals remain on the machine when changing the bowls
- Air gap shaft seals in WIP version (wash-in-place by automatic rinsing with water during cleaning)
- Outlet housing can be swung open for cleaning and inspection
- PLC with operator terminal Siemens TP 1200
- Current and power measurement for granulation end point



P/VAC 10 - 60
in moveable design.



P/VAC in 50 l-Vacuum drying design.



Control hardware arranged for
easy maintenance.

The DIOSNA laboratory mixers P/VAC 10 - 60 are designed as flexible laboratory/pilot scale machines. Different bowls can be added at a later stage. Machines initially designed as pure mixers/granulators can also be extended later to incorporate vacuum drying. The vacuum drying bowls are of cylindrical design and equipped with gas-stripping nozzles, the cover is operated pneumatically. One of the main rotor tips is extended to form a scraper to prevent deposits on the bowl wall, as with the production machines. Thus easy scale-up is assured.

Pharmaceutical Mixer P 100 and P 150*

- Permanently-installed mixing bowls (also 12 bar shockproof)
- Compact, user-friendly design, with integrated operating terminal
- Separate control cabinet with PLC
- Pneumatic safety locking for the bowl cover
- Stand alone or "through-the-wall" installation
- Air gap shaft seals in WIP version (wash-in-place by automatic rinsing with water during cleaning)
- Outlet housing can be opened for cleaning and inspection
- In combination with WIP/CIP and containment valves suitable for processing highly active substances
- Available for direct coupling with our CAP fluid-bed processors

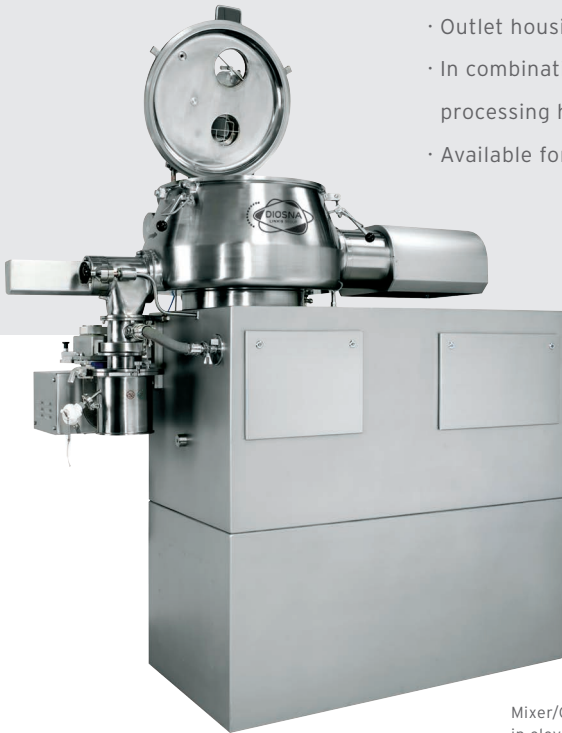

Mixer/Granulator P 150
in elevated design with
wet mill.



Mixer/Granulator P 100.



Cleaning: automatic sealing and
bowl rinsing.

The powerful DIOSNA Pharma Mixers P 100 and P 150 have been designed for use in pilot plants and for smaller production batches. They offer various options for charging with powders and liquids and different versions for setting up, cleaning and control as well as for coupling to sieving mills and dryers.

The Pharmaceutical Mixers P 100 and P 150 are designed to satisfy the highest requirements down to the last detail. Special equipment and individual components for specific applications are available, depending on the requirement.

* Please find information on the gas-stripping vacuum dryer VAC 150 in our separate product brochure.

Mixing, granulation and vacuum drying

Laboratory System P/VAC RC



The laboratory system RC is characterised by a very quickly and easy exchange of the process units.

The through the wall concept saves space in the GMP area and allows for an easy cleaning. It is ideal for combination with an appropriate fluid bed processor and for use under containment conditions.

- Rapid Change (RC) design for quick exchange of the process units
- Through the wall design
- The machine consists of the stationary basis and moveable mixing units
- Drives, WIP valves and controls in the technical zone
- Stainless steel rear panel with operator interface
- Process units for mixing and granulating of 10-80 l
- Process units for vacuum drying 20 and 50 l
- Air gap shaft seals in WIP version
(wash-in-place by automatic rinsing with water during cleaning)

P/VAC RC

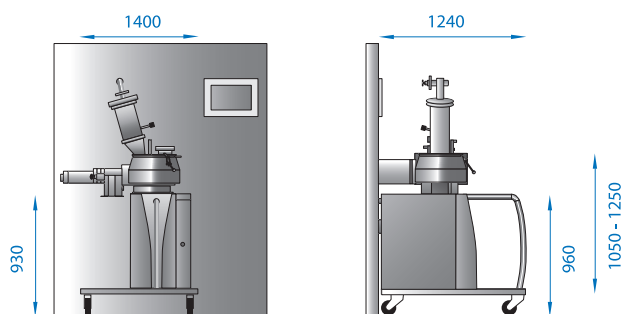

Technical Data	P/VAC RC
P-bowl sizes (l)	10; 25; 60; 80
VAC-bowl sizes (l)	20; 50
Mixer motor power (kW)	4 opt. 5,5
Impeller tip speed (m/s)	0,7 - 7
Chopper motor power (kW)	1,5
Chopper speed (min - 1)	300 - 3000
Weight (kg)	700

We reserve the right to alter the above specifications.

Technical Data

P 1 - 6

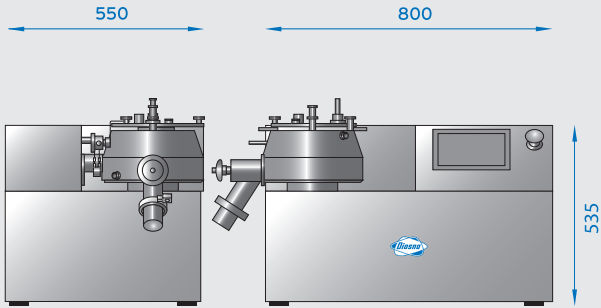

Technical Data	P 1 - 6
Dimensions (W x D x H) (mm)	550 x 800 x 520
Bowl sizes (l)	0,25; 0,5; 1; 2; 4; 6
Mixer motor power (kW)	1,0
Impeller tip speed (m/s)	0,7 - 7
Chopper motor power (kW)	0,18
Chopper speed (min - 1)	220 - 2.200

P/VAC - 10

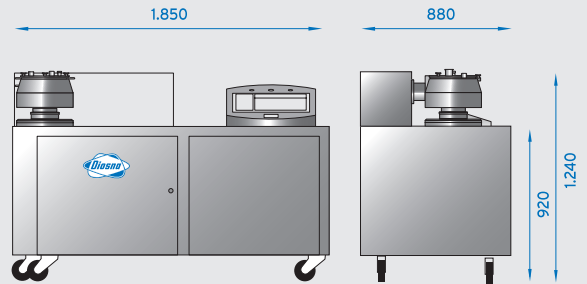

Technical Data	P/VAC - 10
P-bowl sizes (l)	0,25; 0,5; 1; 2; 4; 6; 8; 10
VAC-bowl sizes (l)	2; 6; 10
Mixer motor power (kW)	1,5
Impeller tip speed (m/s)	0,7 - 7
Chopper motor power (kW)	0,75
Chopper speed (min - 1)	220 - 2.200
Weight (kg)	700

P/VAC 10 - 60

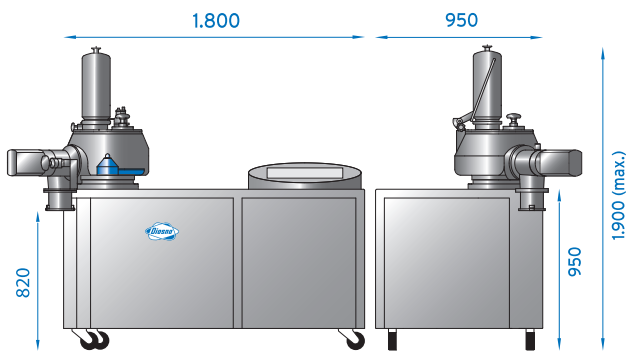

Technical Data	P/VAC 10 - 60
P-bowl sizes (l)	10; 25; 60
VAC-bowl sizes (l)	20; 50
Mixer motor power (kW)	4
Impeller tip speed (m/s)	0,7 - 7
Chopper motor power (kW)	1,5
Chopper speed (min - 1)	300 - 3.000
Weight (kg)	1.000 - 1.100

P 100 and 150

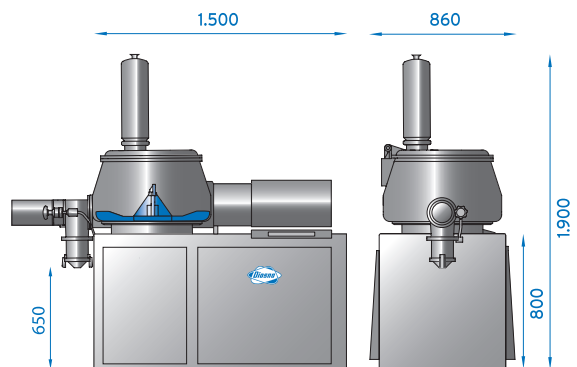

Technical Data	P 100	P 150
Bowl sizes (l)	120	170
Mixer motor power (kW)	5,5	7,5
Impeller tip speed (m/s)	0,7 - 7	0,7 - 7
Chopper motor power (kW)	2,8 / 3,5	2,8 / 3,5
Chopper speed (min - 1)	1500 / 3000	1500 / 3000
Weight (kg)	1000	1000
Control-Cabinet (WxDxH)	1.200 x 500 x 2.200 mm	1.200 x 500 x 2.200 mm
Pneumatics-Cabinet (WxDxH)	800 x 500 x 2.200 mm	800 x 500 x 2.200 mm